

Performance

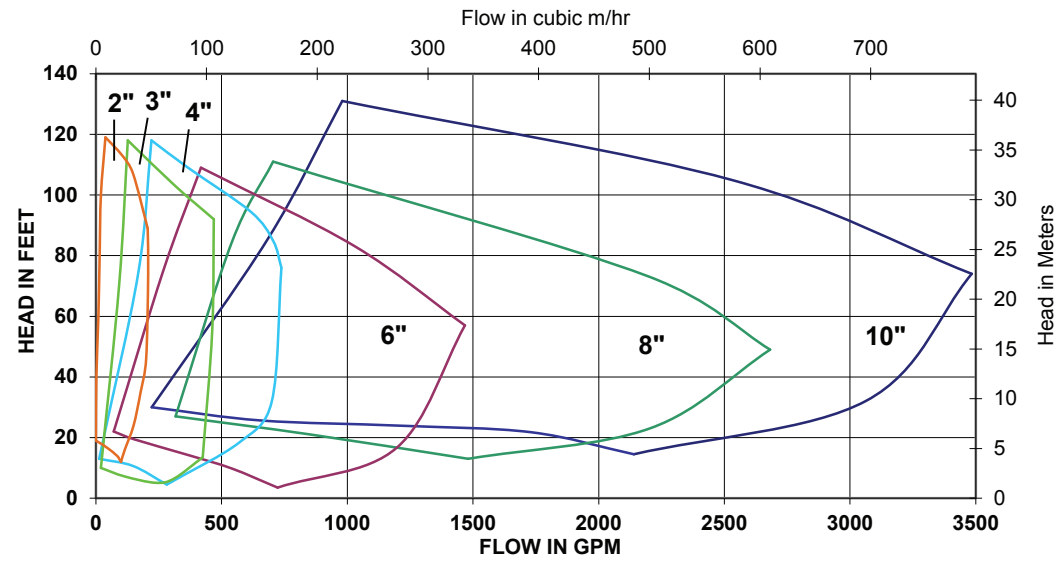

Pump Size	2"	3"	4"	6"	8"	10"
RPM Range	650 to 2900	650 to 2150	650 to 1950	650 to 1750	650 to 1550	650 to 1750
Max Solids	1.5"	2.5"	3"	3"	3"	3"

*Reference published pump curve for specific pump selection

Dimensions

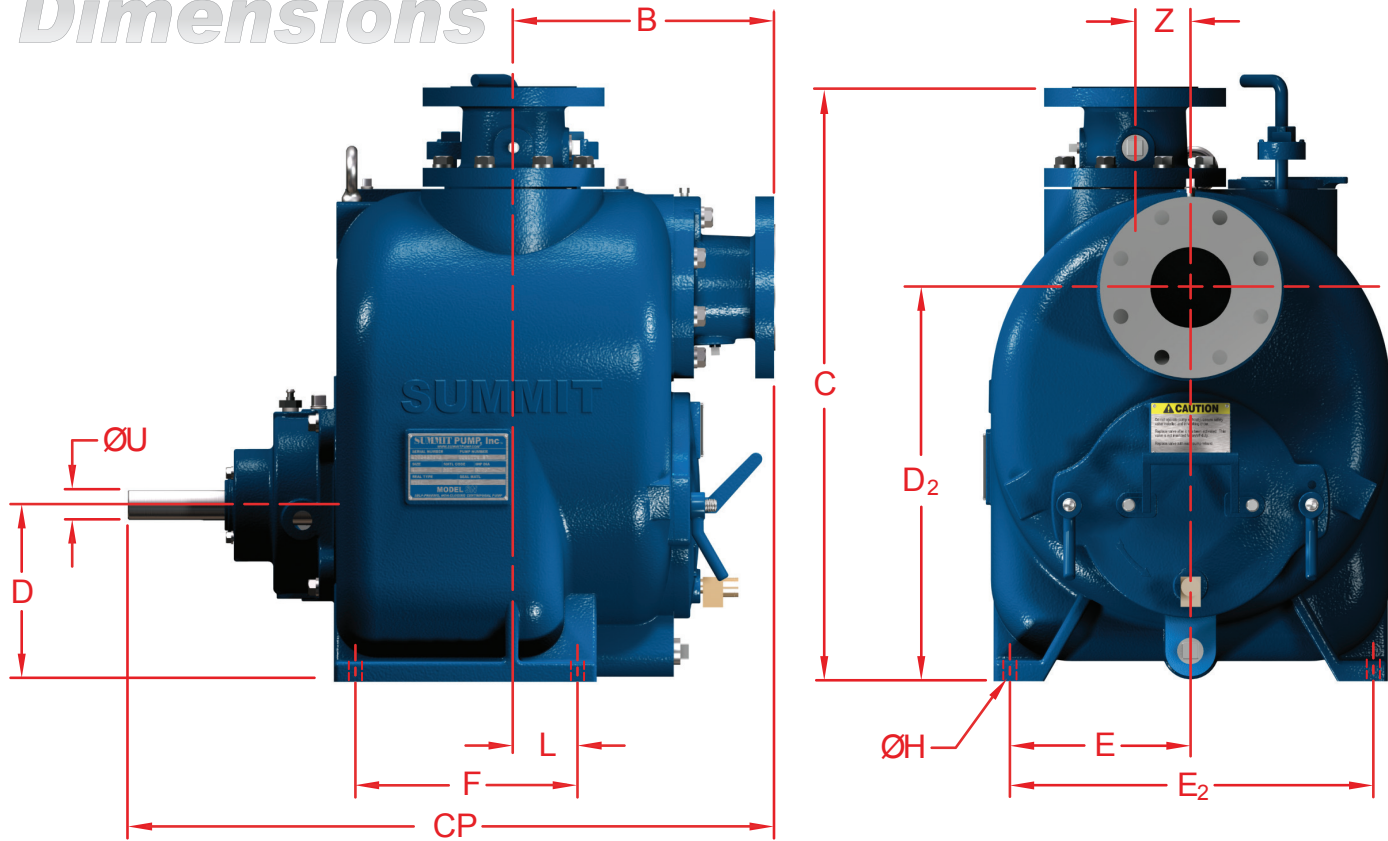

PUMP FRAME	SIZE			D	U	C	CP	B	L	D ₂	Z	FOOT PATTERN				APROX PUMP WT (LBS)
	DIS	SUC	IMP									F	E	E ₂	H	
SN02	2	2	6.38	5.96	1.50	20.63	24.00	9.50	2.12	12.51	2.75	6.38	5.56	11.13	0.50	292
SN03	3	3	8.75	7.50	1.50	27.06	28.75	11.56	3.00	17.00	2.75	9.00	7.75	15.50	0.69	432
SN04	4	4	9.75	8.75	1.50	29.25	32.00	12.50	3.06	19.50	2.75	11.00	9.00	18.00	0.69	664
SN06	6	6	12.38	10.12	1.50	35.31	35.50	16.00	3.06	22.38	2.75	11.00	10.38	20.75	0.69	934
SN08	8	8	14.75	13.00	1.75	42.06	40.28	16.25	4.00	28.50	0	12.00	12.50	25.00	0.88	1710
SN10	10	10	14.75	14.00	1.75	48.81	48.71	28.00	4.00	25.06	0	12.00	12.50	25.00	0.88	1050

SUMMIT™

SN

SN



Self-Priming Non-Clogging



SUMMIT™
PUMP, Inc

www.SUMMITPUMP.com

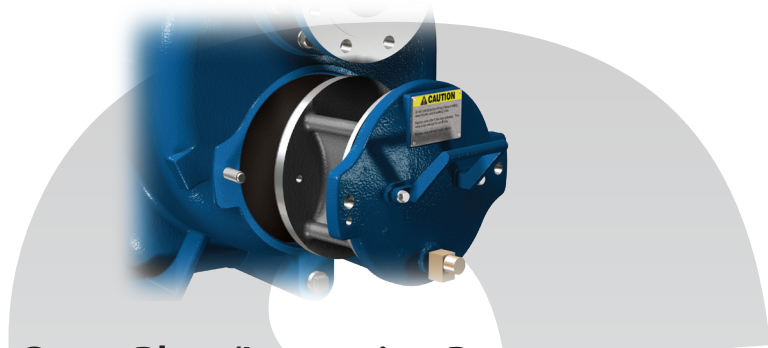

Cover Plate/Inspection Port:

The cover plate is designed to make cleaning and/or inspecting the pump quick and simple, without disconnecting any piping.

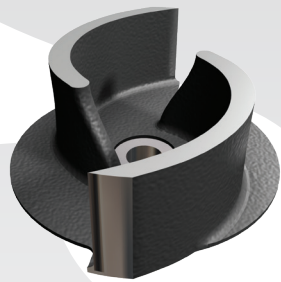

Impeller:

Semi-open, two vane non-clog type impeller handles as large as 3" solids. The presents of shrouds on the backside of the impeller reduce material build-up and reduce pressure on seal and bearings, resulting with longer time between maintenance.

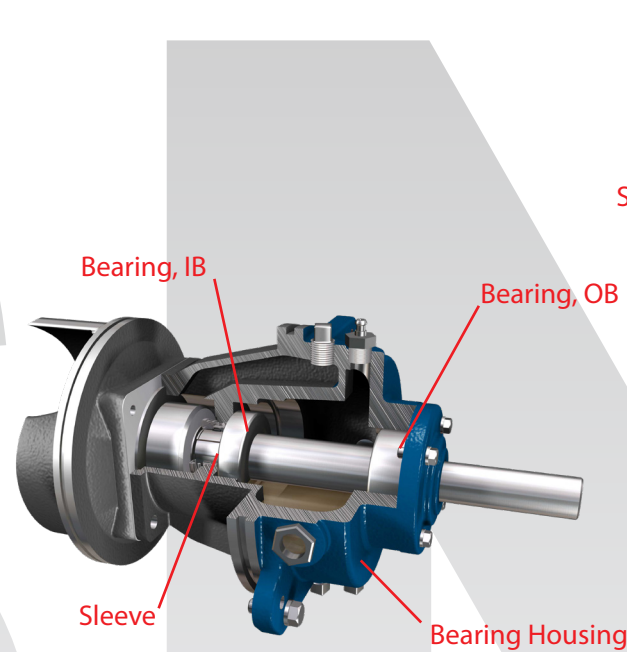

Rotating Assembly:

Maintenance is made extremely easy with all rotating parts removable without disturbance to pump case or piping. One enclosed unit of the bearings, oil and shaft gives you the ability to make inspections while keeping all internal parts sterile. A replacement rotating assembly can be installed, giving you the lowest possible down time.

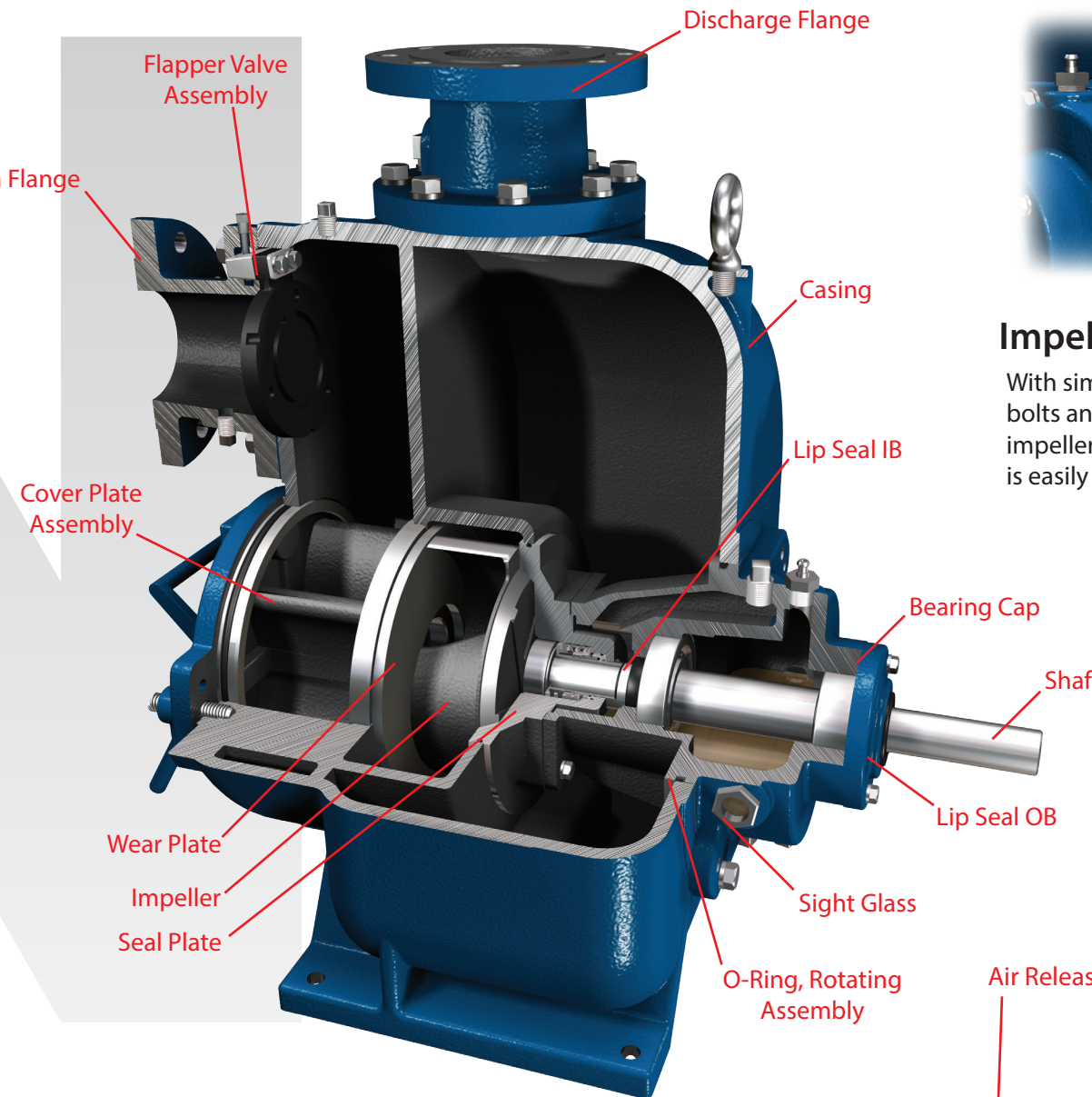

Impeller Clearance:

With simple adjustments to the hex bolts and use of feeler gages, the impeller clearance to the wear-plate is easily adjusted.

Additional Features

These self-priming centrifugal pumps are designed for economical use with solid handling, slurries and mild corrosives utilizing Stainless or CD4 materials. Available in 6 different sizes: 2", 3", 4", 6", 8" and 10". The casing is specifically engineered for a large volume of liquid retention giving, SN pumps superior priming and re-priming dependability.

Priming is done automatically after the initial prime, with no need for suction or discharge check valves. The ability to overcome air in the pump is no obstacle compared to other centrifugal pumps. With the addition of an air release valve the chances of a priming failure is remote.

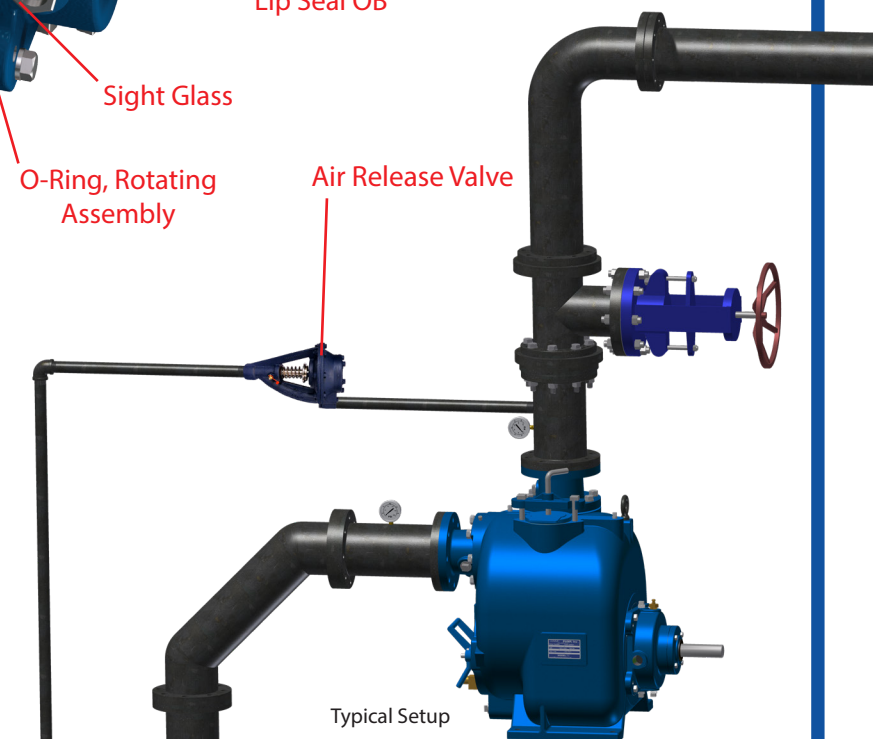

Typical Setup



SUMMIT PUMP, Inc

www.SUMMITPUMP.com